

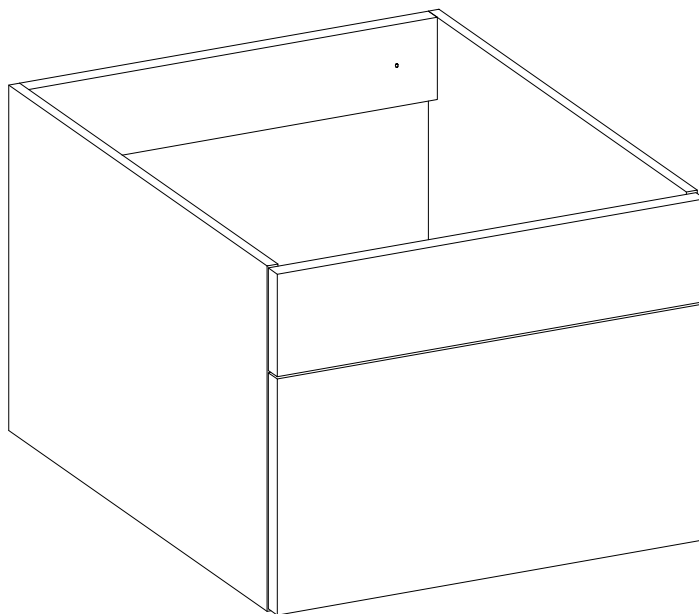







PORTO 302

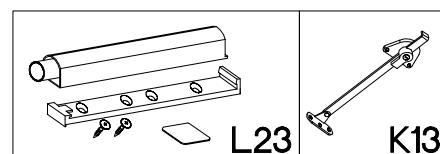
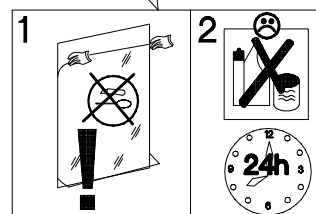
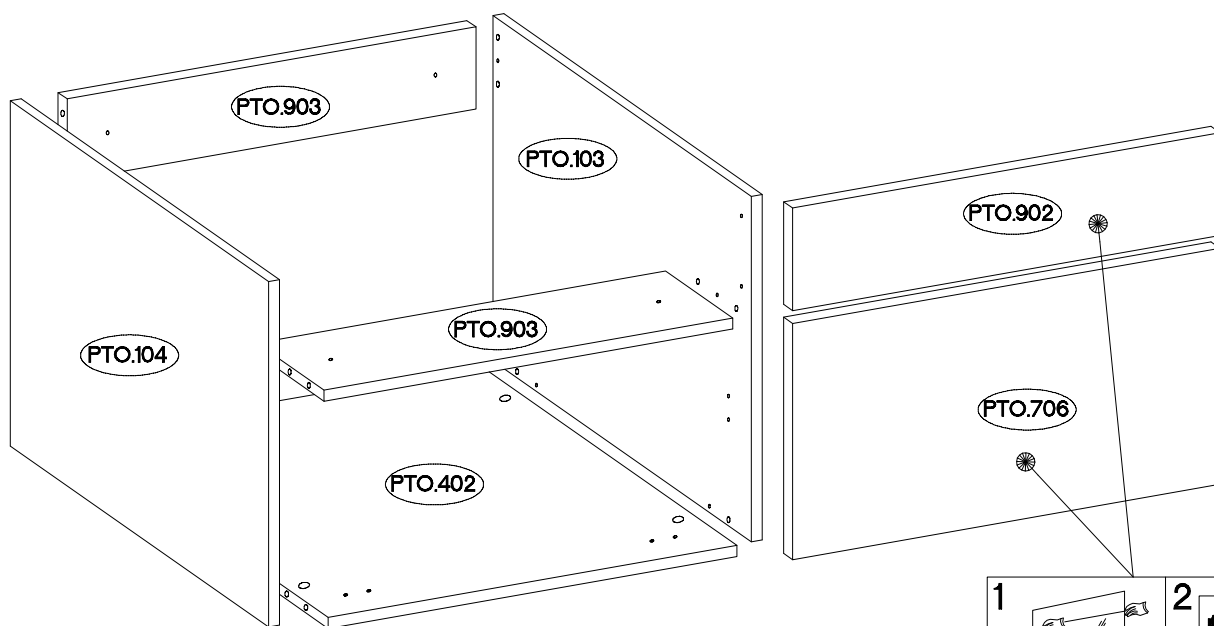

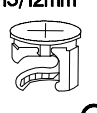
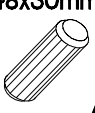
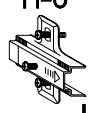
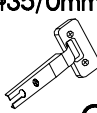

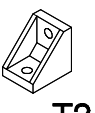

PTO.402 =  max. 2kg



L=20mm  D2 8	±15/12mm  C 8	±8x30mm  A 12	H=0  H 2	±35/0mm  G 2	±3.5x13mm  P5 7	 E 4	 T3 4	 P1 8	 P11 3
--	---	---	--	--	---	--	--	--	---

1

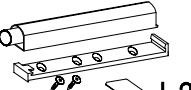
L=20mm  D2	±15/12mm  C	±8x30mm  A	 T3	±4.0x16mm  P1	 L23
8	8	12	4	4	1

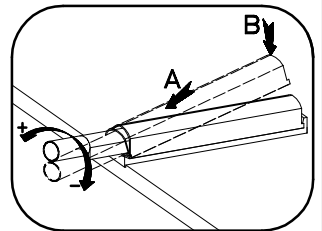
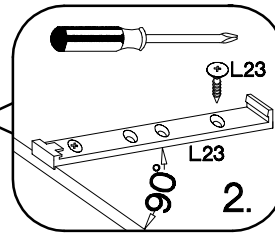
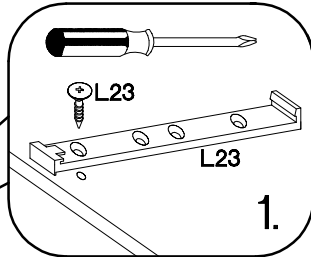
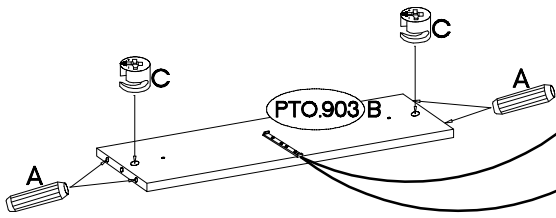
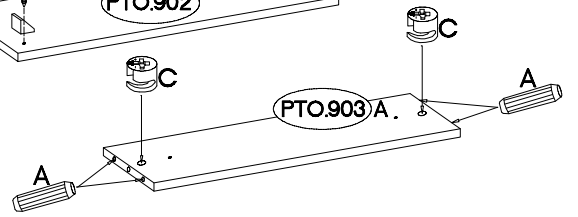
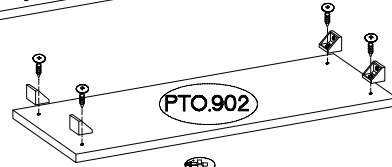
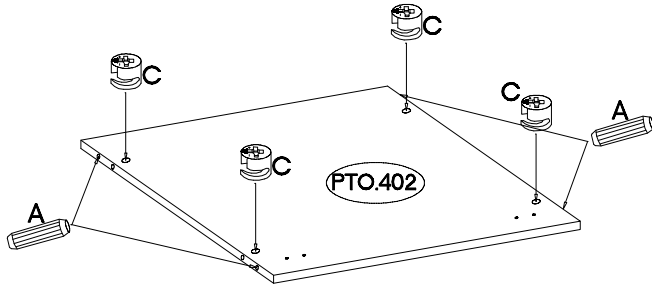
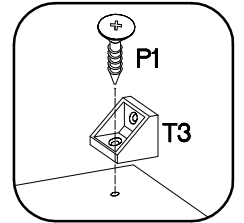
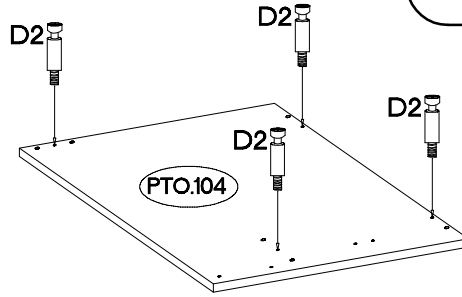
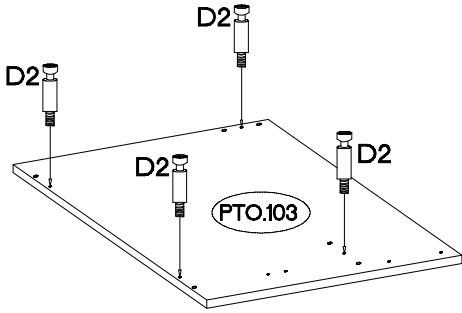
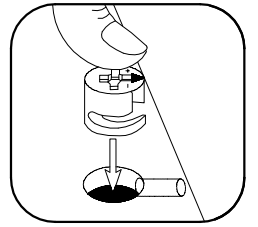
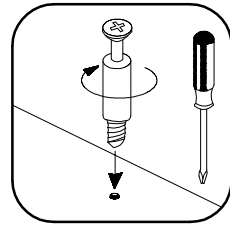

2

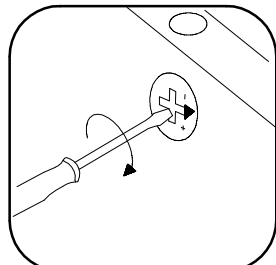
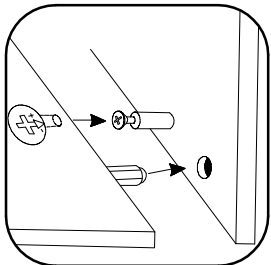
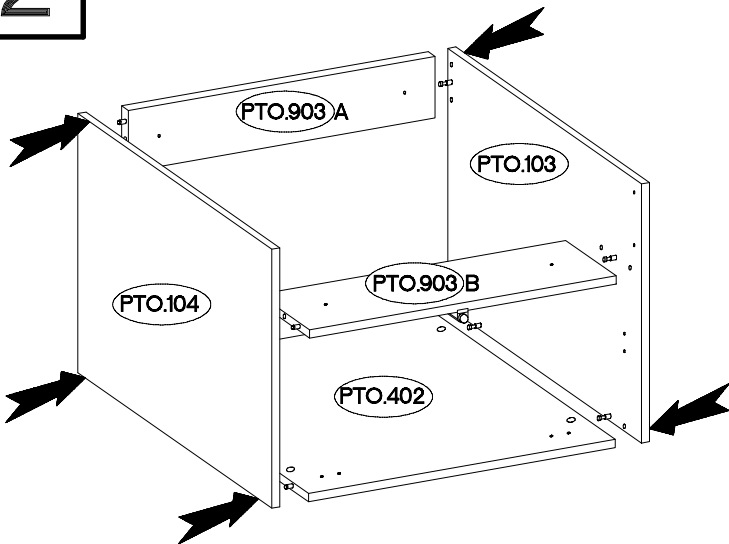

3

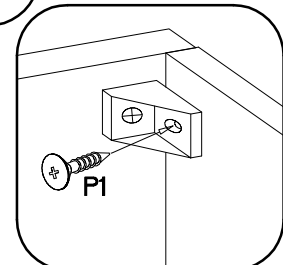
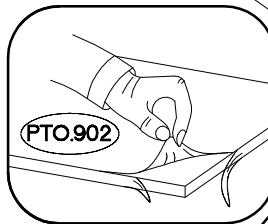
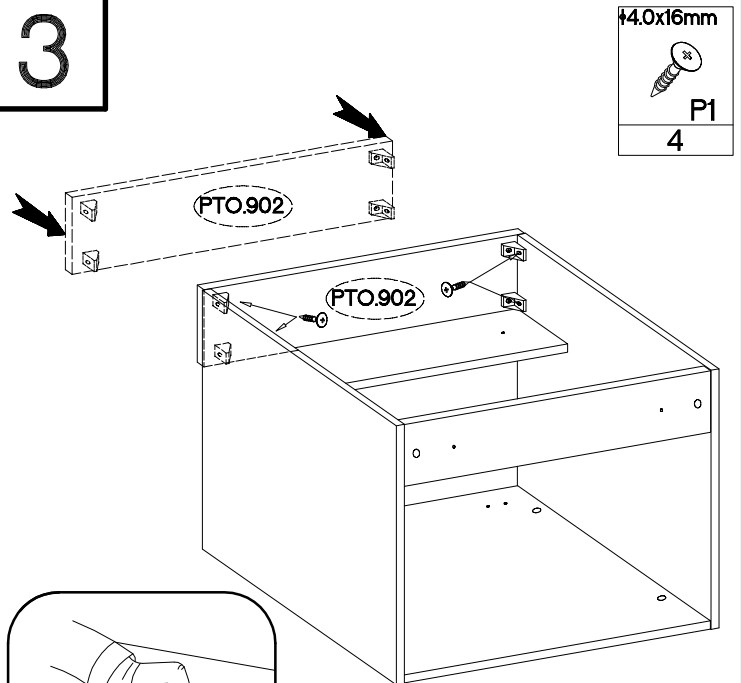

4

±35/0mm



G

2

H=0

±3.5x13mm



H



P5

2

4

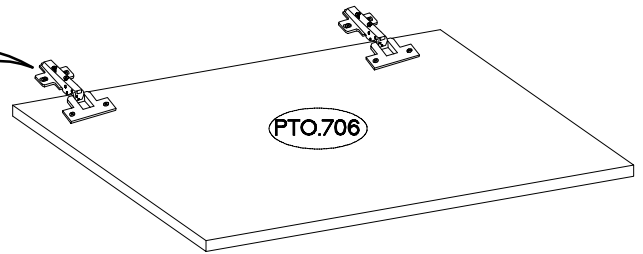
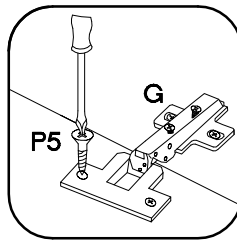
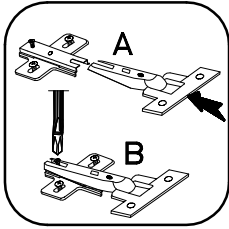

5

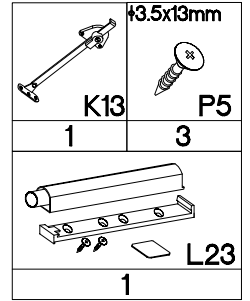
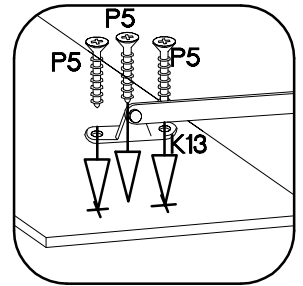
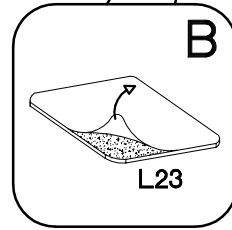
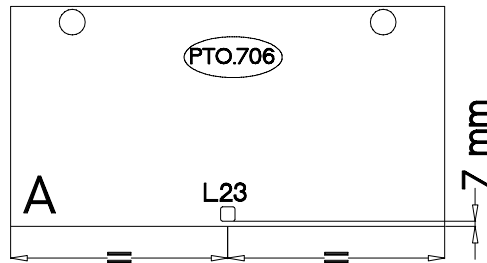
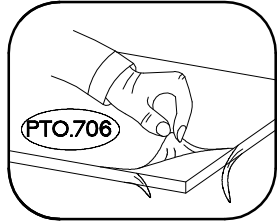
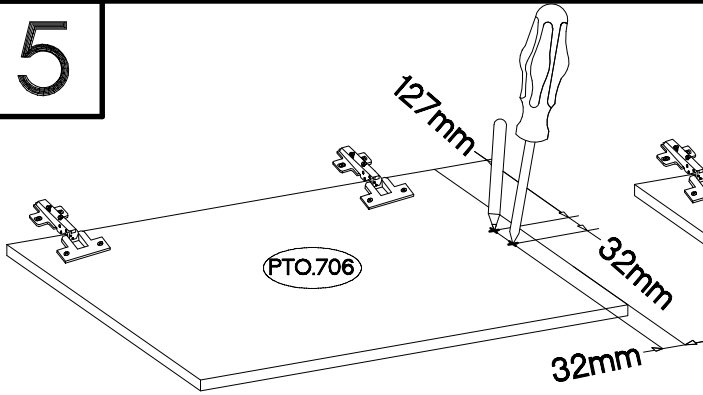

6

